

# User guide

## Profoto A1

For other languages visit:  
[www.profoto.com](http://www.profoto.com)





# Congratulations on your new Profoto product!

Regardless if you chose a new flash or a new light shaping tool, know that almost half a century's worth of experience was put into its making.

If the years have taught us one thing, it is to never neglect a single detail. We only put our name on a product in which we have the fullest confidence. Before shipping, every one of our products passes an extensive and strict testing program. Unless it complies with the specified performance, quality and safety, it is a no-go.

As a result, we are confident that your new Profoto product will stay with you for years and help you grow as a photographer. But getting the product is only the beginning of that journey. Using it for light shaping is the real adventure. That is why we take pride in providing you with such a wide assortment of light shaping tools, allowing you to shape the light in any way you can imagine.

The almost infinite possibilities might seem bewildering at first, but we're certain you will soon get the hang of it.

I encourage you to sign up for our newsletter or visit Profoto stories, [www.profoto.com/profoto-stories](http://www.profoto.com/profoto-stories), to learn more about shaping light from photographers who are sharing their stories about how Profoto Light Shaping Tools help them to create outstanding images.

Enjoy your Profoto product!

Conny Dufgran, founder

# General safety instructions



## Safety Precautions!

Do not operate the equipment before studying the instruction manual and the accompanying safety. Make sure that Profoto Safety Instructions is always accompanied the equipment! Profoto products are intended for indoor conditions use. Do not place or use the equipment where it can be exposed to moisture, extreme electromagnetic fields, or in areas with flammable gases or dust! Do not expose the equipment to dripping or splashing. Do not place any objects filled with liquids, such as vases, on or near the equipment. Do not expose the equipment to hasty temperature changes in humid conditions as this could lead to condensation water in the unit. Do not connect this equipment to flash equipment from other brands. Front lens shall be changed if it has become visibly damaged to such an extent that their effectiveness is impaired, for example by cracks or deep scratches. Equipment must only be serviced, modified or repaired by authorized and competent service personnel



## WARNING - Electrical Shock Hazard - High Voltage!

Do not open or disassemble flashes, generators or lamp heads! Equipment operates with high voltage. Generator capacitors are electrically charged for a considerable length of time after being turned off. Batteries (battery pack or batteries installed) shall not be exposed to excessive heat such as direct sunlight, fire, or the like.



## Caution - Burn Hazard - Hot Parts!

If front lens cracks, it must be replaced before re-use of the equipment. Do not touch front lens during operation it may reach high temperature.

## NOTICE

### Note about RF!

This equipment makes use of the radio spectrum and emits radio frequency energy. Proper care should be taken when the device is integrated in systems. Make sure that all specifications within this document are followed, especially those concerning operating temperature and supply voltage range. Make sure the device is operated according to local regulations. The frequency spectrum this device is using is shared with other users. Interference cannot be ruled out. Due to varying regulations and limits on radio transmissions Profoto's A1 has a power output setting. Some countries does not allow use of the full power mode, please refer to your country specific section in the user guide to see the maximum allowed power setting allowed by national regulations. Please note that reducing the power output will affect the range of the device.



### Laser radiation

IEC 60825-1, Edition 2.0 (2007-03). Wavelength at room temperature: 660 nm. Power through 7 mm aperture at 100 mm distance in front of the exit window of the autofocus assist unit at room temperature: < 300  $\mu$ W. Complies with 21 CFR 1040.10 and 1040.11 except for deviations pursuant to Laser Notice No. 50, date June 24, 2007.

Caution: Do not remove, disassemble or manipulate the laser auto focus assist light. Failure to comply with this caution might lead to possible exposure to hazardous laser radiation.



### Final Disposal

Equipment contains electrical and electronic components that could be harmful to the environment. Equipment may be returned to Profoto distributors free of charge for recycling according to WEEE. Follow local legal requirements for separate disposal of waste, for instance WEEE directive for electrical and electronic equipment on the European market, when product life has ended!

# Table of Contents

General safety instructions.....	4
Introduction .....	6
About the product.....	6
Getting started.....	10
Battery charging.....	10
Attach battery to flash .....	11
Attach light shaping tools .....	11
On-camera use in TTL mode .....	12
On-camera use in manual mode .....	12
Off-camera use.....	13
Operation.....	14
Power on/off.....	14
Mode selection (TTL or Manual) .....	14
Energy scale .....	15
Operation in TTL mode (Automatic mode) .....	15
Operation in MAN mode (Manual mode).....	17
Modeling light .....	18
Activate/deactivate flash head .....	19
Manual zoom.....	19
Test sync.....	20
Using the flash off-camera .....	20
Change settings .....	20
General notes on Profoto Air operation .....	26
Light shaping.....	28
Dome Diffuser.....	29
Bounce Card.....	30
Wide Lens.....	31
Additional functions.....	33
Firmware upgrade.....	33
Factory reset.....	33
Profoto Air compatibility .....	34
Technical data.....	35
Warranty.....	37
Regulatory information .....	38

# Introduction

## About the product

We have designed the A1 to be the world's smallest studio light.

It is designed to provide a beautiful light with great light shaping capabilities and also being incredible easy to use.

We have made the head round to create a circular and natural light pattern. We have a soft and even light fall off that makes it easy to control and set the light creatively. In addition to that we have a range of dedicated Light Shaping Tools that are easily clicked on with a magnetic mount.

---

**6**

The A1 has also AirTTL Remote and receiver built-in, which means it will automatically communicate with other freestanding Profoto lights wirelessly and it can also be used off-camera. This makes it easy to grow in a system and grow with light shaping.



1. Flash head
2. Zoom ring
3. LED Modeling lights
4. Battery
5. Battery release button
6. AF (auto focus) assist structured laser light
7. Hot shoe connector
8. USB port



- |   |                     |
|---|---------------------|
| 9. Display  | 13. Dial            |
| 10. Mode switch (TTL or MAN).<br>Only active when A1 is<br>on-camera. | 14. Settings button |
| 11. Group buttons (A, B, C, D)  | 15. MODEL button    |
| 12. TEST button & ON/OFF<br>button                                    | 16. Lock ring       |



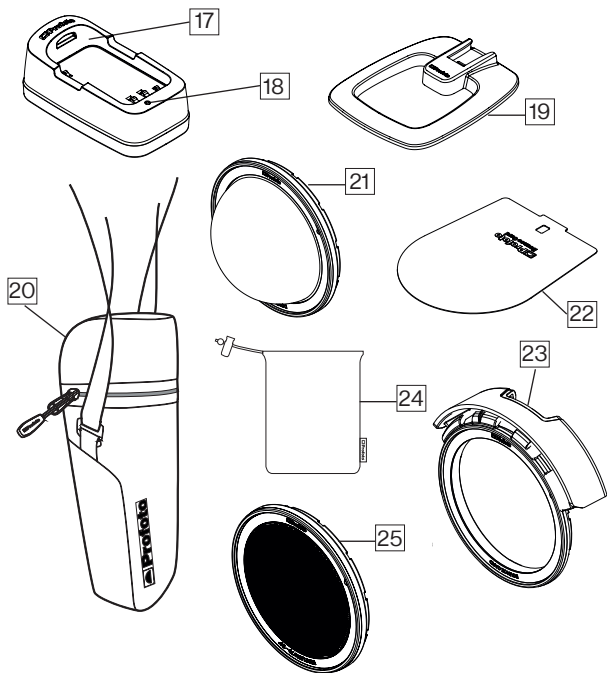

17. Battery charger

18. Battery charger indicator

19. Flash stand

20. Bag

21. Dome diffuser

22. Bounce card

23. Bounce card holder

24. Bounce card pouch

25. Wide lens

## Getting started

### Battery charging

For optimal performance, the battery should be fully charged prior to usage. The battery can be charged from any charge level. For increased life-time, do not leave the battery uncharged for a long time.

Charge the battery:

1. Push the battery release button [5] and remove the battery from the flash. This can be done while the A1 is mounted on the camera.
2. Connect the battery to battery charger [17]

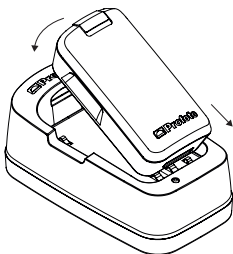

3. Connect the battery charger to mains power.
4. Check that the charge indicator [18] is continuously orange, indicating that charging is in progress.
5. When the charging is completed, the charge indicator [18] is green.

#### Note:

If the battery is deeply discharged, the charging time can be longer than specified in section Technical data.

Battery blinking orange indicates battery error. Contact your local Profoto dealer for support.

## Attach battery to flash

Connect the bottom part of the battery to the flash and then press it in place until you hear a "click".

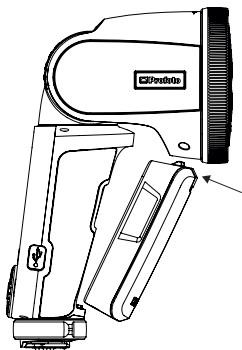

## Attach light shaping tools

The dedicated light shaping tools are easy and quick to attach. Just snap them in place in front of the flash lens until you hear a "click". To remove them, just pull them off.

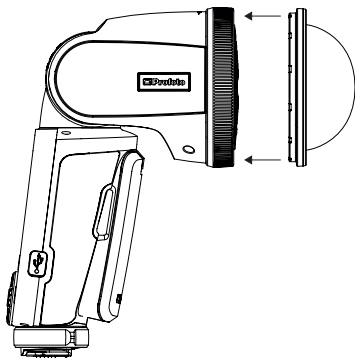

## On-camera use in TTL mode

1. Slide the hot shoe connector [7] on the A1 into the hot shoe of the camera. Turn the locking mechanism to secure.
2. Switch on the A1.
3. Turn the dial [13] clockwise to unlock.
4. Use the mode switch [10] to select TTL mode.
5. Take an image with the camera and the flash will adjust its power to get a correct exposure.
6. Use the dial [13] to adjust the flash exposure compensation. This can also be done in camera by changing the flash exposure compensation.

TIP: You can at all time switch to manual mode and keep the setting from the last TTL flash. This is extra helpful when you need to lock the flash exposure and keep it constant.

### Note:

TTL is only available in group A-C and group D-F are always manual mode, even if switch [10] is set to TTL mode.

## On-camera use in manual mode

1. Follow step 1-3 above
2. Use the mode switch [10] to select MAN (Manual) mode.
3. Take an image to check the exposure or use the test button [12] and light meter to measure the exposure.
4. Use the dial [13] to adjust the light output to your preferences.

TIP: To improve efficiency, use TTL for first shot and then switch to manual to lock the flash exposure. By doing this you get correct exposure quickly and then you can fine tune flash exposure in manual mode.

## Off-camera use

This describes how to operate an A1 unit off-camera and with an A1 unit on camera as transmitting unit. When A1 is used off-camera together with an Air Remote on camera, please see instruction manual for Air Remote how to adjust the flash from on-camera position.

1. Switch on the A1.
2. Turn the dial [13] clockwise to unlock.
3. Turn on Air and select the same radio channel on the A1 unit as on the transmitting unit on the camera.
4. Select a group for the A1 flash.
5. Take an image to check the exposure or use the test button [12] and light meter to measure the exposure in manual mode.
6. Adjust overall flash exposure compensation with dial [13] or in camera menu.
7. To adjust an individual light, select the group on the group buttons [11] you like to adjust on the transmitting unit and adjust energy by rotating the dial [13]. This can both be done in TTL- and manual mode.
8. In manual mode, the energy setting can also be done on each unit individually.

### Note:

When A1 is used as off-camera unit, the TTL/MAN switch (10) will be overridden. Selecting TTL or manual is used on the trigger unit on camera.

## Operation

Mounted in the camera hot shoe, the A1 unit acts both as an on-camera flash and as a wireless extension of your camera to your Profoto off-camera flashes, combining TTL (Through-The-Lens) exposure control with the option to manually adjust and sync your Profoto flashes.

### Power on/off

- Push the ON/OFF button [12] to switch on the A1.
- Push and hold the ON/OFF button [12] to switch off the A1.

When the A1 is switched off, the current settings (except for TTL) are stored and will apply when the unit is switched on again.

To save battery, the A1 automatically enters standby mode after a period of inactivity (selectable via the standby setting) and switches off completely after 90 minutes. These functions can be deactivated via the standby setting.

In standby mode, the display [9] and test button [12] are switched off. To return to operational mode, push any of the A1 buttons or use the camera.

#### Note:

When the standby and auto power off functions are deactivated, the batteries will drain in approx. 8 hours of inactive use.

### Mode selection (TTL or Manual)

Use the mode switch [10] to select TTL or or MAN mode. The mode switch is only active for the on-camera unit. When the A1 is used off-camera, the function of the switch is disabled and the on-camera unit will dictate to all off-camera units if TTL or manual mode is used.

- TTL mode: The camera dictates the light output of the flashes. The relation between the energy levels for group A-C and flash exposure compensation can be set up from the A1.
- MAN mode: The light output for group A, B and C can be controlled manually from the A1.

#### Note:

By pressing a group twice all groups will be selected and highlighted. All settings done will now apply to all groups A, B, C, D, E and F.

## Energy scale

The A1 unit has a relative f-stop scale to indicate the energy level. Full energy, 100% is always shown as 10.0. Decreasing 1-fstop means reducing the energy to half, hence energy 9.0 is 50% of total energy.

Energy can be adjusted in precise 0.1f-stop increments.

## Operation in TTL mode (Automatic mode)

### Adjustment of energy level relations

In TTL mode the camera dictates the light output of the flashes. If more than one light is used the relationship between the energy levels of group A, B and C can be adjusted. This can, for example, be used to achieve more light on one side of the object.

1. Press the A, B or C group button [11] to select the corresponding group.
2. When a group is selected, do one or more of the following:
  - Use the dial [13] to set the relative light output for the selected group, in relation to the other groups. The relations can be set to +/- 2 f-stops for each group A, B or C.
  - Press the MODEL button [15] to turn on/off the modeling light in the selected group.
  - Press and hold the group button [11] to turn on/off the lamp heads in the selected group. (If the heads in a group are turned off, the relation value for that group will display '--'.)
  - The display automatically returns to the main menu after a few seconds.

### Note:

If flashes without Profoto AirTTL support are used in combination with Profoto AirTTL flashes in TTL mode, the flash outputs of the non-TTL flashes are added to the total flash exposure. Such flashes can for instance be used to manually set the exposure on the background.

If a Profoto AirTTL compatible flash is set to group D, E or F, it will be synchronized but not part of the TTL calculation. The flash outputs of these flashes are added to the total flash exposure and can for instance be used to manually set the exposure on the background.

## Flash exposure compensation

As an alternative to the flash exposure compensation function in the camera, the A1 can be used to compensate the total flash exposure when in TTL mode.

Use the dial [13] to adjust the flash exposure compensation  $\pm 3.0$  f-stops.

## Display view in TTL mode



Example of Display [9] settings in TTL mode operation

The figure shows an example of the display view in TTL mode when:

- AIR is activated and channel 1 is selected. The A1 flash unit is set to belong to group B.
- TTL mode is selected. The flash exposure compensation is set to -1.4 f-stops.
- The energy is set to 4.3. In TTL mode the energy will be set automatically for each flash.
- The energy relation between the groups is shown above each group. In TTL mode the numbers only show the relation between the groups. The absolute flash exposure is set by the flash exposure compensation, either in the flash or in the camera.
  - The relative light output from lights in group A is set to 2.6 f-stops more than lights in group B and 0.8 f-stops more than group D.
- Group B is selected to be adjusted.



- Lights in group C are turned off
- Group D has no offset and will be 0.8 f-stops less than lights in group A and 1.8 f-stops more than lights in group B
- The modeling light is turned on in group A and on A1 unit.

## Operation in MAN mode (Manual mode)

With the A1 set to MAN mode, the light output for the groups A, B, C, and D can be adjusted manually.

- Select group(s) by doing one of the following:
  - Press the A, B, C, or D group button [11] to select the corresponding group.
  - To select all groups, press one of the group buttons [11] twice. When all groups are selected, the A1 will also control the lights in group E and F (selected on the flash).
- When a group is selected, do one or more of the following:
  - Use the dial [13] to adjust the light output for the group. The adjustment always starts from the current light output setting (displayed as 0.0 above the group indicator) and the adjustment value (e.g. +1.2) is momentarily shown above the group indicator.
  - Press the MODEL button [15] to turn on/off the modeling light in the selected group.
  - Press and hold the group button [11] to turn on/off the flashes in the selected group.
  - The display automatically returns to the main menu after a few seconds.

### Note:

If a light output cannot be set by the flash because it is outside its energy range, the A1 beeps to signal that the command was not executed. The light output of all flashes in the selected group then remains unchanged.

## Display view in MAN mode



Example of Display [9] settings in MAN mode operation

18

The figure shows an example of the display view in MAN mode when:

- AIR is activated and channel 1 is selected. The A1 flash unit is set to belong to group B.
- The energy for the A1 flash is set to 3.3.
- The A1 modeling light is turned on.
- Group B is selected to be adjusted and the energy has been changed with +1.1 f-stop.
- Lights in group C are turned off
- The modeling light is turned on in group A and on A1 flash unit.

### Modeling light

To turn on the modeling light on A1, press MODEL button [15].

To turn on modeling light on a specific group, first select group A, B, C or D and then press MODEL button [15].

When the A1 modeling light is on, a white dot is displayed to the right on the display and/or on the different groups.

## Activate/deactivate flash head

The flash head can be deactivated without turning off the power of the A1 unit. This is used when the A1 should work as a remote control for off-camera flashes but no flash itself.

Press and hold the MODEL button [15] to turn on/off the A1 lamp head.

When the A1 lamp is off, '--' is shown in the center of the display [9].

### Note:

The A1 flash head can also be activated/deactivated in the settings menu.

## Manual zoom

The beam angle from the flash can be adjusted at any time to match your preferences. You can for example narrow the light to highlight part of the image.

Rotate the Zoom ring [2] on the flash head clockwise or counter clockwise to change the beam angle.



## Test sync

To test the flash or take meter readings with a light meter the test button will fire a flash on the A1 unit. If Air is activated it will also fire test flashes on all flashes on the selected channel.

Press the test button [12] to manually transmit a sync signal and fire the flash.

## Using the flash off-camera

The A1 unit is easy to use also as an off-camera flash unit as it has a built in radio transceiver (AirTTL). The transmitting unit in the camera hot shoe can be either an A1 unit or an Air Remote.

1. On the transmitting unit in the camera hot shoe, enable Air and set channel.
2. On the off-camera unit, enable Air and set channel to the same as on the transmitting unit.

## Change settings

All settings are easily accessed in the settings menu.

For detailed information about the different settings, see the subsequent sections.

1. Push the settings button [14] to display the settings menu.
2. The menu is split between main functions and secondary functions for fast and easy access. Press rightmost group button [11] to select next page in the menu.

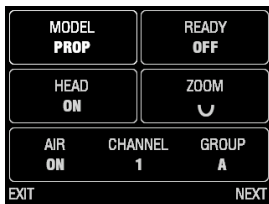

- Turn the dial [13] to select (highlight) a setting.



- Press the settings button [14] to display the options menu for the selected setting.
- Turn the dial [13] to change the setting option.
- Press the settings button [14] to choose option and return to the settings menu.
- Press the leftmost group button [11] to select EXIT and return to the main menu.

## Modeling light

The modeling light is a constant light source positioned in the flash head. The angle of the light (light spread) will follow the zoom setting on the flash. Use the modeling light to analyze shadows or as a help to position your subject in relation to the flash.

The model setting is used to select how the A1 modeling light intensity should correspond with the flash light output.

## 22

There are three setting options for the A1 modeling light:

- **MIN:** The A1 modeling lamp gets the half intensity, regardless of the selected energy level (light output).
- **MAX:** The A1 modeling lamp gets the maximum intensity, regardless of the selected energy level (light output).
- **PROP:** The A1 modeling light intensity is automatically adjusted to be proportional to the selected light output (energy level).

## Ready

Ready signaling is used to indicate when the A1 flash is fully recycled.

There are four ready signaling options:

- **BEEP:** The A1 unit beeps when it is ready to flash again after recharging. This option will also enable key sound.
- **DIM:** The A1 modeling light turns off after flashing and turns on when the A1 unit is ready to flash again.
- **BEEP DIM:** The A1 modeling light turns off after flashing. The A1 modeling light turns on and the A1 unit beeps when it is ready to flash again.
- **OFF:** No ready signal.

The test button [12] always comes off after flashing and comes on again when the A1 flash is fully recycled.

## Sync

The selected sync setting (camera sync setting) is shown in the top of the display [9].

There are three sync options:

- 1st: The flashes fire when the first shutter curtain is fully open.
- 2nd: The flashes fire just before the second curtain starts traveling.
- Hi-S: HSS (High Speed Sync/Auto FP) mode is selected.
- X-Sync: Maximizes frame rates per second in continuous shooting. All communication except sync signal is disabled between the flash and the camera and because of this the flash will only operate in manual mode.

HSS enables shooting with flash at a faster shutter speed than the fastest external flash sync speed (x-sync) of the camera, all the way down to 1/8000s (may differ between camera models). This option can be extremely useful to limit the influence of ambient light when shooting in bright conditions.

### Note:

The sync setting (1st, 2nd and Hi-S) works slightly different for Canon and Nikon. In Canon you can change the setting in both camera and on flash unit. On Nikon, the sync settings are only done in camera. Refer to the camera's user guide for how to change sync settings in camera.

The A1 unit can be used on other camera brands in X-sync mode if the camera has a hot shoe with a central positioned sync contact. This is standard for most cameras today. In this mode the camera will be a full manual flash without TTL- or HSS compatibility. Other functions that are controlled from the camera will also be disabled.

## Group

The group setting (A-F) applies to the A1 flash.

The selected group is shown in the top of the display [9].

## Channel

The channel setting (1-8) applies to the A1 control unit and the A1 flash.

The selected channel is shown in the top of the display [9].

## Air

The Air setting is used to activate/deactivate the built-in Profoto Air transceiver.

- ON: The A1 can be used to trigger and/or control Profoto Air flash units and generators, including the A1 flash.
- OFF: The A1 can only be used to control the A1 flash.

## Head

The head setting is used to activate/deactivate the A1 flash head. By doing this the flash will not fire when it receives a sync signal. This function works both on -and off-camera.

## Backlight

The backlight of the display [9] has an impact on the battery time.

There are three backlight options:

- MIN
- MEDIUM
- MAX

## Standby

There are three standby options:

- 2 min: Standby mode is entered after 2 minutes of inactivity.
- 30 min: Standby mode is entered after 30 minutes of inactivity.
- OFF: Standby mode is disabled. This setting also disables the auto power off function.



## Zoom

The zoom (beam angle) setting applies to the A1 flash.

The following zoom options are available:

- **Manual:** The beam angle is adjusted manually, by turning the zoom ring [2].
- **Auto:** The beam angle of the A1 flash light will automatically follow the zooming on the camera.
- The beam angle of the A1 flash can be set to five different beam angles, from wide to narrow.

### Note

If a light shaping tool is attached to A1, the beam angle will be different

## AF assist

The AF (autofocus) assist setting activates or deactivates the AF assist. The AF assist light works with a structured laser light which is harmless to the eyes.

- **OFF:** Deactivates the AF assist
- **AUTO:** The camera activates the AF assist automatically when needed
- **ON:** Activates the AF assist so that it is always on.

## General notes on Profoto Air operation

The Profoto Air channels [1-8] use eight specific frequencies in the 2.4 GHz band and have an operating range of up to 300 meters (1000ft). The frequencies are evenly distributed over the entire frequency band. Since each channel uses a different radio frequency, it is possible to select a channel without interference from other photographers using Profoto Air, WLAN/Bluetooth devices, or other radio equipment operating on the 2.4 GHz frequency band.

- Maintain line of sight between the Air Remote TTL-C/N and the flash unit whenever possible
- When hiding the flash from view, try to not hide it behind or against metal or water-filled objects as this will affect the radio range.







## Light shaping

The A1 flash creates a round and even light spread in all zoom positions. In addition, there are specially designed light shaping tools for the A1 that can modify the light quality in various ways.

When A1 is used on camera it can automatically follow the zoom setting on the lens. For creative freedom the beam angle can also be set manually, either in the menu or by rotating the zoom ring [2]. When the zoom ring [2] is used the beam angle setting will automatically go to manual mode. The current beam angle setting is shown in the top of the display [9].

The zoom setting on the flash corresponds approximately to the following focal length coverage for a 35mm camera.

Beam angle setting	Focal length coverage	
	A1 without accessories	A1 with wide lens
	105 mm	24mm
	80 mm	
	60 mm	18mm
	45 mm	
	32 mm	14mm

## Dome Diffuser

The Dome Diffuser attaches to the A1 unit with the built in magnetic mount. The light quality will be diffused and spread omni directional. This is often used when bouncing the light in the ceiling to get a softer and less directional light. Direct the flash head against the surface to bounce off from.

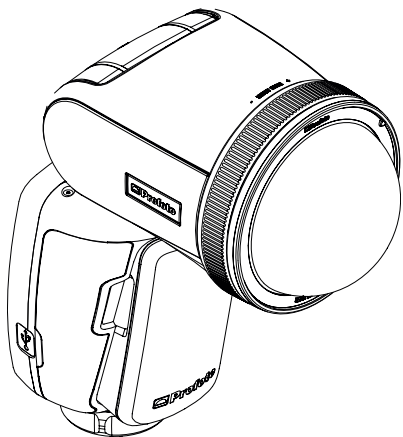

### Note:

The Dome Diffuser can also be stacked together with other light shaping tools. For example the optional Gel can be used in combination with the Dome Diffuser.

## Bounce Card

The Bounce Card attaches in the same way as the Dome Diffuser with a magnetic mount. The application is similar to the Dome Diffuser but will provide a more directional light quality.

To attach the Bounce Card to its holder, squeeze the sides of the Bounce card slightly and then push it firmly into the holder until the card locks in place.

30

In most cases the flash is directed against a bouncing surface and the bounce card is directed against the subject.

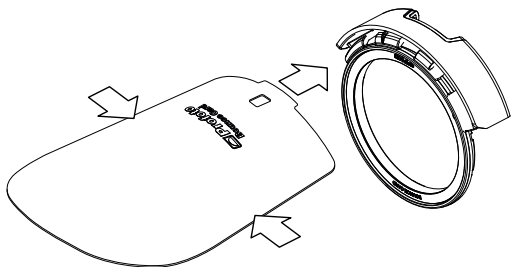

### Note:

The Bounce Card can also be stacked together with other light shaping tools. For example the optional gel can be used in combination with the Bounce Card.

## Wide Lens

The Wide Lens is used when a wider light spread is needed, for example when using super wide lenses. The built in zoom function of the A1 unit will still work which means beam angle can be adjusted from super wide to wide light spread.

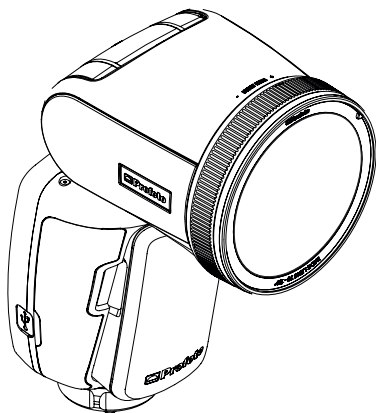





# Additional functions

## Firmware upgrade

We recommend that you look for firmware upgrades before you start using your new A1.

To access the latest free upgrades; create your personal account on [profoto.com/myprofoto](http://profoto.com/myprofoto). Once you have an account you can also choose to register your products and be sure you get noticed when new upgrades are released.

Upgrade of firmware is made via the USB port [8] on the A1, following the instructions provided in the upgrade application downloaded from [profoto.com/myprofoto](http://profoto.com/myprofoto). You can always contact your local dealer or distributor for professional service.

Check current firmware version:

1. Switch on the A1.
2. Push settings button [14] and then to second page in the menu.
3. Select VERSION by pressing settings button [14]

## Factory reset

To reset all settings to default:

1. Switch on the A1.
2. Push settings button [14] and then to second page in the menu.
3. Select VERSION by pressing settings button [14]
4. Push the rightmost group button [11] to select RESET.

## Profoto Air compatibility

- The Profoto A1 AirTTL-C is specifically designed for Canon cameras that use Canon's E-TTL II metering system.
- The Profoto A1 AirTTL-N is specifically designed for Nikon cameras that use Nikon's i-TTL metering system.
- Some camera models may not be supported or have limited functionality. Check [profoto.com](http://profoto.com) for the latest information on camera support.
- The Profoto A1 AirTTL operates with Profoto flash units and generators, with built-in Profoto Air functionality according to the table below.
- The Profoto A1 AirTTL can also be used to trigger the Air Remote and Air Sync Profoto Air transceivers.
- The Profoto A1 AirTTL flash can also be triggered and controlled by other Profoto Air transceivers.
- The Profoto A1 AirTTL-C is not compatible with Canon Speedlites or other non-Profoto flashes.
- The Air Remote TTL-N is not compatible with Nikon Speedlights or other non-Profoto flashes.
- The Profoto A1 AirTTL is not compatible with any 3rd party radio triggering systems.

Air labeling on Profoto flash	Enabled features on Profoto A1 AirTTL			
	Manual sync	Remote control	TTL	HSS
AirTTL	X	X	X	X
Air	X	X		
AirS	X			

## Technical data

### Specifications

Frequency band	2.4GHz (2404 to 2479.3 MHz)
No of frequency channels	8 (1-8)
Radio Power Output	Maximum 19.9 dBm
No of groups per channel	TTL operation: 3 (A-C) Manual operation: 6 (A-F)
Operation modes	TTL, Manual
Camera TTL compatibility	A1AirTTL-C - Canon E-TTL II A1AirTTL-N - Nikon i-TTL
Sync modes	1st curtain, 2nd curtain, Hi-S (HSS/ Auto FP), X-Sync
Camera mount/Connectors	Hot shoe mount for Canon/Nikon USB micro connector for firmware upgrades
Range	Up to 300 m (1000 ft.) for normal triggering Up to 100 m (330 ft.) for remote control and TTL
Flash energy	76Ws
Flash energy range	9 f-stops (2-10)
Flash recycling time	0.05 – 1.2 seconds
Flash duration	1/20,000 - 1/800
Energy stability	0.2 f-stop
Color stability	±150°K
Modeling lamps	LED

---

**Specifications**

---

Battery type	Li-ion
Battery charging time	80 minutes
Battery capacity:	Up to 350 full power flashes
LCD display	Yes
Standby	Enters standby mode after a period of inactivity (2 min, 30 min, OFF).
Auto power off	Turns off after 90 minutes of inactivity (can be deactivated).

---

**Supported Profoto Air functionality**

---

Flash Sync/Trigger	Yes, A1 triggers Air Remote and Air Sync transceivers plus all Profoto labeled AirTTL, Air and AirS.
Remote control	Yes, A1 works as a manual remote control for all Profoto flashes labeled AirTTL and Air.
TTL control	TTL with group control for all Profoto flashes labelled AirTTL.

---

**Measurements (LxWxH)**

---

Dimensions	108x75x165 mm
Weight (including battery)	560g

---

All data are to be considered as nominal and Profoto reserves the right make changes without further notice.

## Warranty

All Profoto generators and heads are individually tested before they leave the company and guaranteed for a period of two years (local deviations may apply) with the exception of flash tubes, glass covers, modeling lamps and cables. Profoto is not responsible for technical malfunctions created by improper use or accessories made by other companies. If you have any technical problems please get in contact with an authorized Profoto service station.

## Regulatory information

### World-wide Usage of Radio Spectrum

The Profoto Air system operates on the license-free 2.4GHz ISM band for SRD (Short Range Devices). This band may be used in most parts of the world. Regional restrictions may apply.

#### Note:

Refer to national regulations for the region where the Profoto A1 AirTTL shall be operated and make sure that they are followed.

## 38 EU Declaration of Conformity

Hereby, Profoto AB declares that the radio equipment type Profoto A1 AirTTL is in compliance with Directive 2014/53/EU.

The full text of the EU declaration of conformity is available at the following internet address: <http://media.profoto.com/DoC>

### RF Power

In order to remain compliant with national regulations and restrictions, please use the following RF POWER settings while operating your A1 in these countries. Please note that these are subject to change and you may find updated information available for download at Profoto.com

COUNTRY	CHANNEL	RF POWER
USA/Canada	CH1-7	P0
USA/Canada	CH8	P4
EU (and EES)	CH1-8	P0
South Korea	CH1-8	P5
Taiwan	CH1-8	P3

To to enter the RF POWER settings, press and hold B and C buttons.

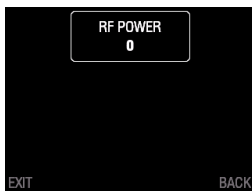

## **Unites States and Canada F.C.C. and Industry Canada**

Compliance Statement (Part 15.19) This device complies with Part 15 of FCC rules and RSS-210 of Industry Canada. Operation is subject to the following two conditions:

1. this device may not cause harmful interference and,
2. this device must accept any interference received, including interference that may cause undesired operation.

### **Warning (Part 15.21)**

Changes or modifications not expressly approved by the party responsible for compliance could void the user's authority to operate the equipment.

Ce dispositif est conforme aux normes RSS-210 d'Industrie Canada. L'utilisation de ce dispositif est autorisée seulement aux conditions suivantes :

1. il ne doit pas produire de brouillage et
2. l'utilisateur du dispositif doit être prêt à accepter tout brouillage radioélectrique reçu, même si ce brouillage est susceptible de compromettre le fonctionnement du dispositif.

The term 'IC' before the certification/registration number only signifies that the Industry Canada technical specifications were met.

Les lettres 'IC' n'ont aucune autre signification ni aucun autre but que d'identifier ce qui suit comme le numéro de certification/ d'enregistrement d'Industrie Canada.

### **Profoto AB**

Transmitter / Receiver

MODEL: Profoto A1 AirTTL

PRODUCT NO: PCA1382-0000 and PCA1381-0000

FCC ID: W4G-RMI6

IC: 8167A-RMI6

Product of Sweden

## South Korea

해당 무선설비는 전파혼신 가능성이 있으므로 인명안전과 관련된 서비스는 할 수 없음.

## Taiwan

經型式認證合格之低功率射頻電機，非經許可，公司、商號或使用者均不得擅自變更頻率、加大功率或變更原設計之特性及功能。

低功率射頻電機之使用不得影響飛航安全及干擾合法通信；經發現有干擾現象時，應立即停用，並改善至無干擾時方得繼續使用。

前項合法通信，指依電信法規定作業之無線電通信。低功率射頻電機須忍受合法通信或工業、科學及醫療用電波輻射性電機設備之干擾。

## Third party copyright & License Terms

Copyright © 2013 Frantisek Burian <BuFran@seznam.cz>

Copyright © 2013 Piotr Esden-Tempski <piotr@esden.net>

LibOpenCM3 is free software licensed under the terms of the GNU Lesser General Public License as published by the Free Software Foundation, either version 3 of the License, or (at your option) any later version. LibOpenCM3 is distributed in the hope that it will be useful, but WITHOUT ANY WARRANTY; without even the implied warranty of MERCHANTABILITY or FITNESS FOR A PARTICULAR PURPOSE. See the GNU General Public License and the GNU Lesser General Public License for more details, <<http://www.gnu.org/licenses/>>. You may obtain a copy of the source code for the LibOpenCM3 under the terms of the LGPL upon written request to Profoto.

Lägg till denna text









Profoto AB  
Sweden

+46 (0) 8 447 53 00  
info@profoto.com  
www.profoto.com



Technical data and product information are subject to change without notice.  
344050, May 2017, Printed in Sweden.